

Worldwide Pollution Control Association

WPCA-Duke Energy

Is Your Precipitator Ready for MATS?

Aug. 28, 2012 – Plainfield

Sept. 11, 2012 - Charlotte

All presentations posted on this website are copyrighted by the Worldwide Pollution Control Association (WPCA). Any unauthorized downloading, attempts to modify or to incorporate into other presentations, link to other websites, or to obtain copies for any other purposes than the training of attendees to WPCA Conferences is expressly prohibited, unless approved in writing by the WPCA or the original presenter. The WPCA does not assume any liability for the accuracy or contents of any materials contained in this library which were presented and/or created by persons who were not employees of the WPCA.



Visit our website at www.wpca.info

W
P
C
A

What are Sorbent Injection Effects on ESP Performance?

by Russ Ridgeway, RE Consulting



SHEL-B Environmental
Emissions Consulting, Inc.

Wasn't Life Simple Then?

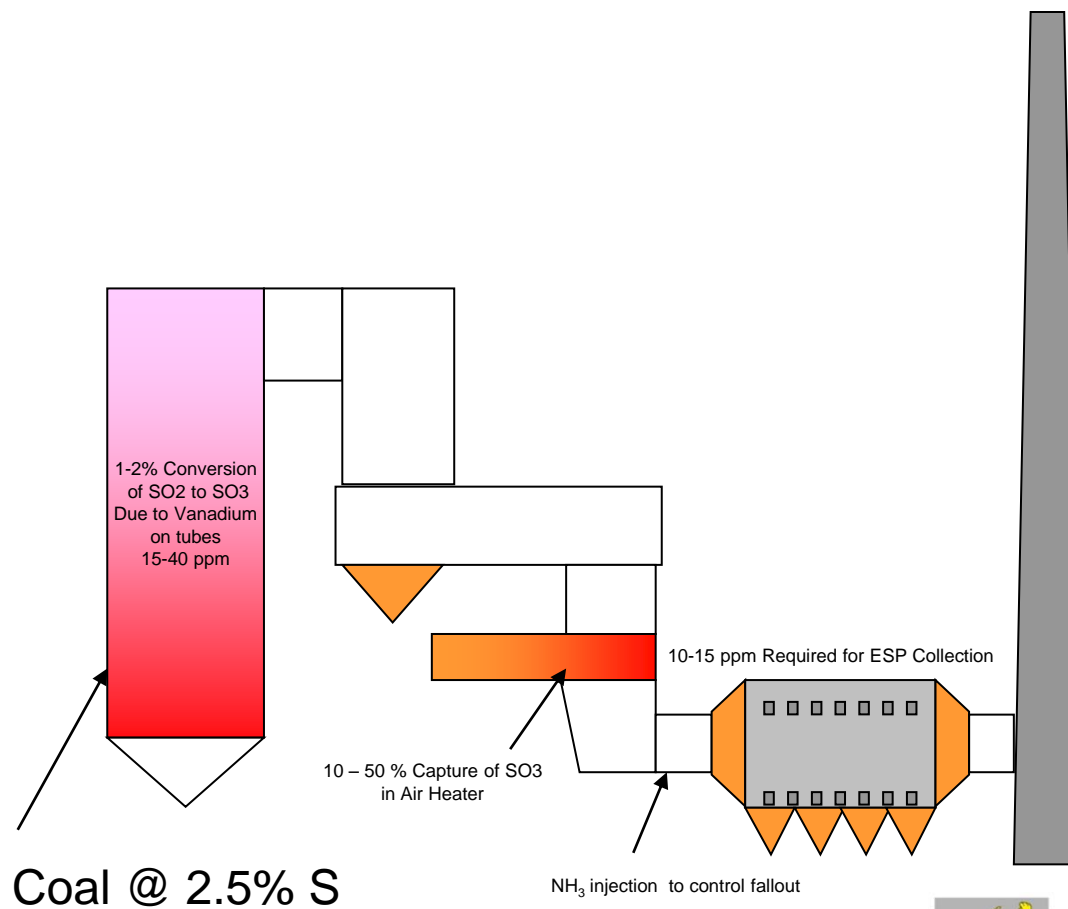

Before We Had These!

Combustion NOx Control

Post-Comb. NOx Control

SO₂ Control

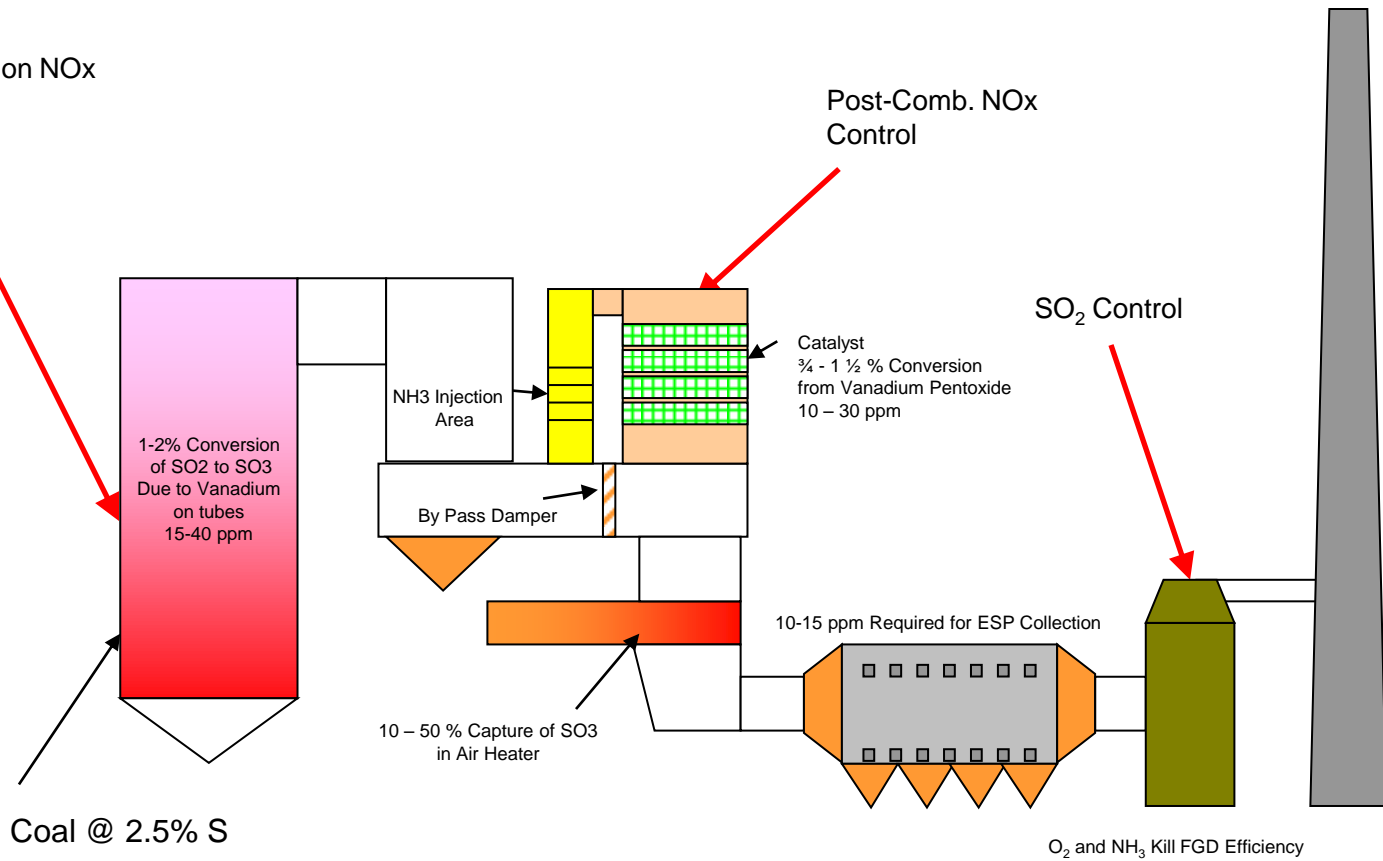

Early Lessons Learned

- Plan Ahead
- Test, Test, Test
- Control Devices Are Not Islands
- What is Good for One is Not Good for ALL
- Temporarily One Can Save Another



What sorbents will you have to use for MATS compliance?

- DSI
- ACI
- Halogens
- Soda Ash



DSI

(Keep them dry)

- Hydrated Lime
(calcium based)
- Sodium Bicarbonate
- Trona
(Sodium Based)
Sticky around 380°F

Used to control SO_3 at several locations. So controlling SO_2 with these may starve the ESP of SO_3 .



ACI

- Average micron 16-20
- Effective Temperature 325°F+
- Moisture 12%

Collecting and rapper re-entrainment of ACI could be an issue.



Halogens

(to enhance the ACI)

- Potassium Bromide
- Calcium Bromide
- Hydrogen Bromide

Expected issue is leaching out into the water.



What aspects will sorbents effect?

Fundamental Design Factors

- Fly Ash
 - Resistivity
 - Particle Size
 - Chemical Composition
- Undersized Precipitator
- Sectionalization
- Rapping System
- FARS Capacity

Operational Factors

- Improper Adjustment of Rapper Intensity or Frequency
- Air Heater Pluggage



Fly Ash Resistivity/Conduction Mechanisms

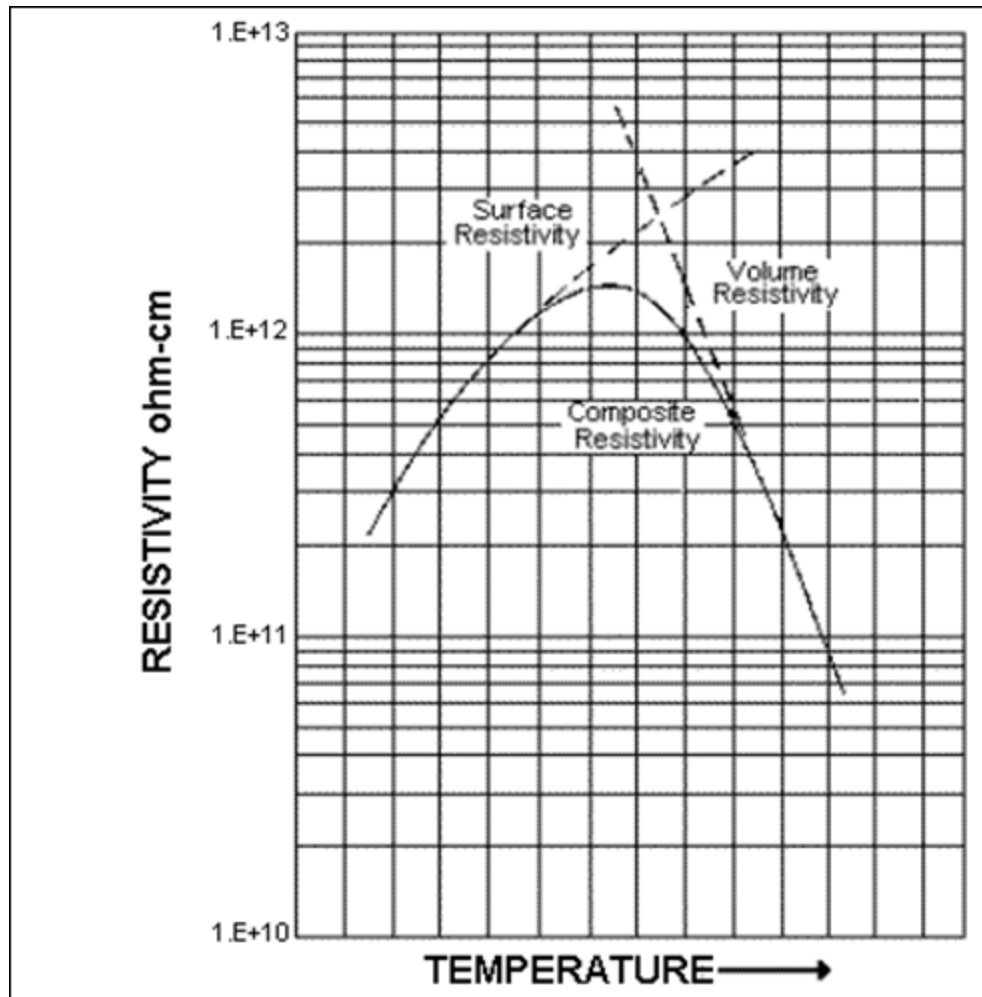

- Fly ash resistivity/conductivity determined by two independent mechanisms
 - Volume resistivity/conduction
 - Surface resistivity/conduction
- Volume resistivity due to conduction through the bulk of the fly ash
- Volume resistivity dominates at higher temperatures



Resistivity Ranges

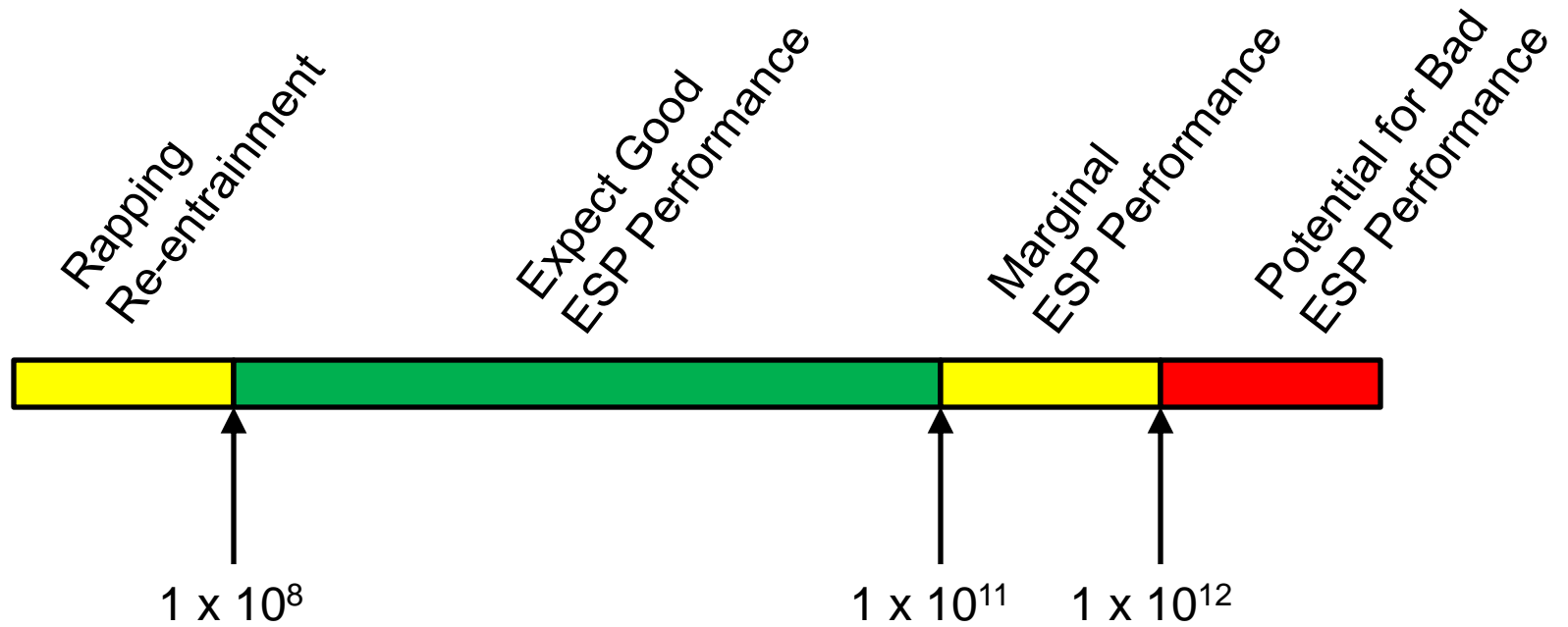

Fly Ash Particle Size

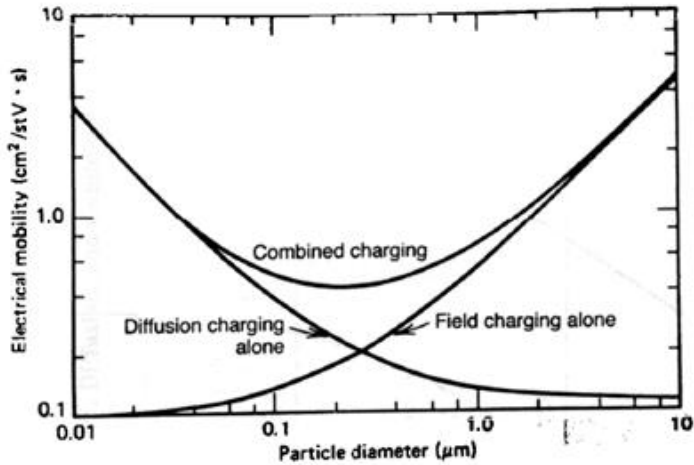

Courtesy of Univ. of FL

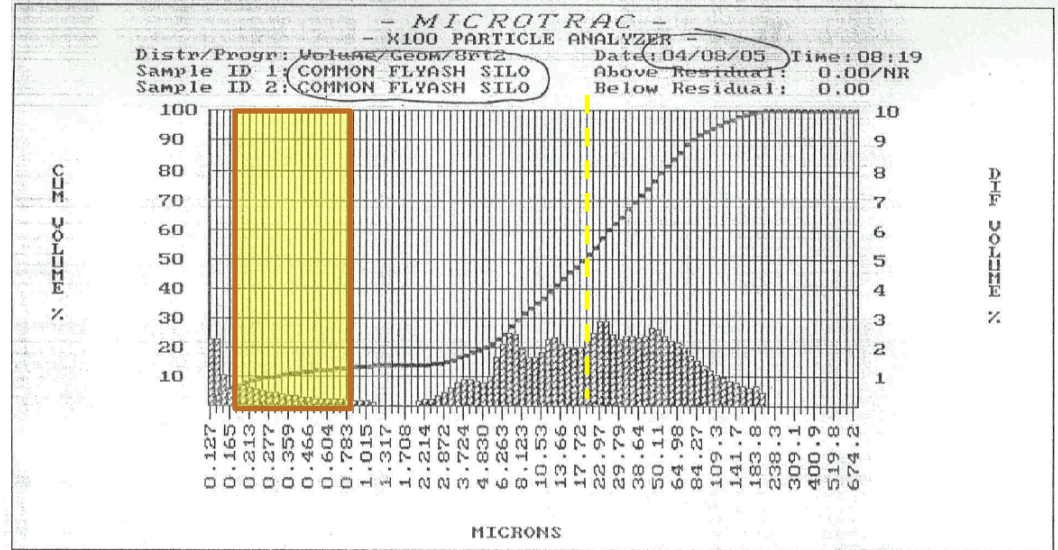

Particle Size (micron)	Volume Fraction	Cumulative Volume %
1	0.12	12
5	0.08	20
15	0.25	45
35	0.23	68
75	0.20	88
160	0.12	100

ESP Collection Efficiency

(Deutsch-Anderson Equation)

$$\eta = 1 - e^{-\frac{A}{V}\omega}$$

Calculated from the known geometry of the ESP and the process design data

A - Collecting Electrode Surface Area

V - Volumetric Flow Rate

ω - Drift or Migration Velocity

$$\omega = \frac{E_o E_p a}{2 \pi g}$$

E_o - Charging Field

E_p - Collecting Field

a - Particle Radius

g - Gas Viscosity



SHEL-B Environmental
Emissions Consulting, Inc.

Sorbent Burden on ESP

- Calcium based sorbents may increase resistivity
- Sodium based sorbents will decrease resistivity
- Increased emissions
- Increased spark rate
- Need for increased rapping interval
- Potential for increased erosion
- Increased hopper fill rate



ACI like Increase in LOI

- Increased spark rate
- Increased re-entrainment
- Potential for insulator tracking
- Potential for hopper fires
- Inability to sell fly ash
- Decreased effectiveness of activated carbon
- Potential increased dust resistivity



What are the numbers?

	250 MW		600 MW		800 MW		1300 MW		1300 MW
	East / MS	East / MS	East / LS	East / HS	East / LS	East / LS	East / HS	East / HS	PRB
Coal (Tons/yr)	523000	523000	1063000	1063000	1832000	1832000	3785000	3785000	5618000
BTU	12050	12050	12163	12163	12112	12112	11989	11989	8801
Ash in Coal	11.5%	11.5%	12.0%	12.0%	11.9%	11.9%	9.1%	9.1%	6.2%
# Ash/MMBTU	9.5	9.5	9.9	9.9	9.8	9.8	7.6	7.6	7.0
<hr/>									
# SO2/MMBTU	1.98	1.98	1.18	4.69	1.18	1.18	6.06	6.06	0.73
Ton of Ash from Coal	60145	60145	127560	127560	218008	218008	344435	344435	345507
Conversion to Fly Ash	80%	80%	80%	80%	80%	80%	80%	80%	85%
Fly ash to ESP	48116	48116	102048	102048	174406	174406	275548	275548	293681
ESP Collection Eff	99.75%	99.75%	99.75%	99.75%	99.75%	99.75%	99.75%	99.75%	99.75%
Ash Emitted	120	120	255	255	436	436	689	689	734
NSR Trigger (tons/yr)	25	25	25	25	25	25	25	25	25
Injection to Trigger NSR *	10000*	10000*	10000*	10000*	10000*	10000*	10000*	10000*	10000*
Percent of Increase to ESP	21%	21%	10%	10%	6%	6%	4%	4%	3%
Post-Combustion Controls									
SCR		Ö	Ö	Ö	Ö	Ö	Ö	Ö	Ö
ESP	Ö	Ö	Ö	Ö	Ö	Ö	Ö	Ö	Ö
Wet FGD		Ö		Ö		Ö		Ö	
DSI	0.10	0.10	0.18	0.32	0.25	0.25	1	1	0 tons/hr
	842	842	1617	2830	2156	2156	8760	8760	tons/yr
ACI w/Halogens	5	0	5		5	0	5	0	5 lb/Macf
	1.5	1.5	2.5	2.5	3.2	3.2	5.1	5.1	5.1 Macfm
	7.5	0	12.5	0	16	0	25.5	0	25.5 lb/m
	1971	0	3285	0	4205	0	6701	0	6701 tons/yr
Total Injected Tons	2813	842	4902	2830	6361	2156	15461	8760	6701
Potential NSR Trigger	No	No	No	No	No	No	Yes	No	No

* - 10,000 Tons is back calculated assuming the DSI and ACI does not change the ESP efficiency.



SHEL-B Environmental
Emissions Consulting, Inc.

Sectionalization

If your ESP is or becomes marginal can you easily resectionalize?

- Do you have dual busing TR Sets?
- Can the high voltage frames be easily divided?
- Do you have the room for more TR Sets either conventional or high frequency?
- Do you have the electrical infrastructure for additional TR sets?



Rapping System

- CE Ratio SQ-FT/Rapper (12-15K)
- DE Linear FT/Rapper
 - Top Rap (RDE -1500, WW-3000)
 - Tumbling Hammer 500
- Low resistivity re-entrainment
 - Rapper Tuning
 - Re-sectionalize
- Power off rapping



FARS

-
- The Forgotten System!!!
 - Misunderstood philosophy
 - Extremely Abused
 - Temperature extremes up to 32 times/day
 - Abrasive material
 - Beaten to make behave

New Challenges

- What is the System Capacity?
- Injection burden will be greatest in the inlet!



Mechanical Factors Affecting Performance

New Issues Directly Related to Injection

- FARS (Full Hoppers)
- Ash Deposits on Gas Distribution Devices
- Excessive Ash Deposits on Electrodes

Existing Problems Exacerbated

- Poor Electrode Alignment
- Vibrating or Swinging Electrodes
- Distorted Collecting Plates
- Air Inleakage
- Gas Sneakage Through Hoppers and Around ESP Zones



DSI Darker Sides



Plate build-up



Inlet Turning Vane
and Nozzle Pluggage



Perforated Plate
Pluggage



Testing of Sorbent Products

- It is highly recommended, but it is not a 100% guarantee if successful.
- A 3 week test is a minimum for the ESP.
- The test should be continuous with a pre and post ESP inspection.
- The more ESP and opacity data the better.
- A PM test during the testing is a must.
- Be aware of what changes are made during the test.



ESP Data During Trona and PAC Testing

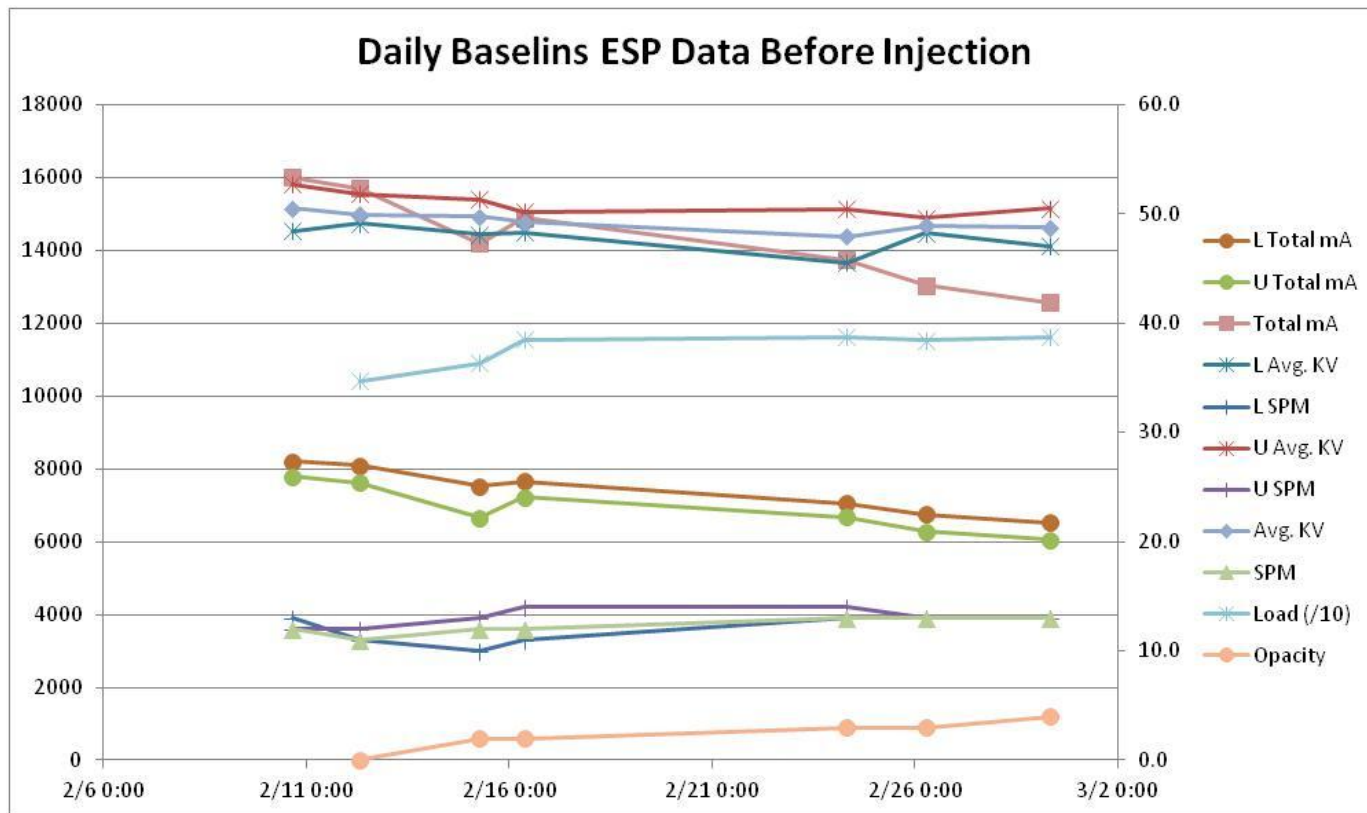

Suggestion for Pre MATS

- Pretest Sorbents to be used.
- Fix known ESP problems up front.
- Check your FARS capacity.
- Upgrade your ESP
 - Sectionalize ESP/Rappers
 - Eliminate Weighted Wires
- How old are your TR sets? Does their replacement play into your game plan?
- Install taps to collect delta-Ps across GDS devices



Operating a Power Plant No Longer Like Driving on a Super Highway



Power Plant Driving
Before 1990 CAA



Upcoming Power Plant Driving
Deadly if you drop off either edge!



SHEL-B Environmental
Emissions Consulting, Inc.